

Development of Grooving Tools “SEC-GND” Series

Yosuke SHIMAMOTO*, Masanobu UEDA, Tomoyuki FUKUYAMA and Junya OKIDA

Grooving is widely applied in the machining of various machine parts including automotive components. However, compared with general cutting, grooving is subject to problems such as difficulty in chip evacuation, which can result in defects on metal surfaces, and tool vibration due to the high load operation with the entire cutting edge. To improve processing efficiency and accuracy while minimizing the cost of grooving tools, Sumitomo Electric Hardmetal Corporation has developed new grooving tools “SEC-GND” series. This series reduces machining vibration by 30% compared with the conventional models, ensures better chip control, and saves tool costs.

Keywords: grooving, vibration, chip control, tool cost

1. Introduction

Grooving is widely applied in the machining of various machine parts including automobile components. However, problems tend to occur more often during grooving than during general cutting; for example, (1) removing chips is difficult, which results in increased clogging by chips and more defects on machined surfaces, and (2) a high load is applied to tools because the entire cutting edge is in contact with the workpiece during grooving, which may cause tools to vibrate. Nevertheless, similarly to other machining processes, there is demand for higher grooving efficiency and accuracy and low-cost grooving tools.

With this background, Sumitomo Electric Hardmetal Corporation has developed the SEC-GND series grooving tools with indexable inserts (**Photo 1**) with the following features to meet users' requirements: (1) high performance in controlling chips (chip control), (2) machining vibration during grooving that is 30% lower than that of our conventional tools, and (3) high economic efficiency. Here we report the features and cutting performance of the SEC-GND grooving tools.



Photo 1. Grooving tools “SEC-GND” series

2. Features of “SEC-GND” Series

2-1 Effective chip control

The SEC-GND grooving tools have different insert chip breakers for deep grooving, multifunction machining (grooving/turning), and profiling (**Photo 2**), and can be used for various machining applications (**Fig. 1**). Moreover, two types of insert chip breaker have been developed for both deep grooving and multipurpose machining (grooving/turning), i.e., those for general feed applications and those for low feed applications, where the latter is used for finishing and other purposes. Thus, the SEC-

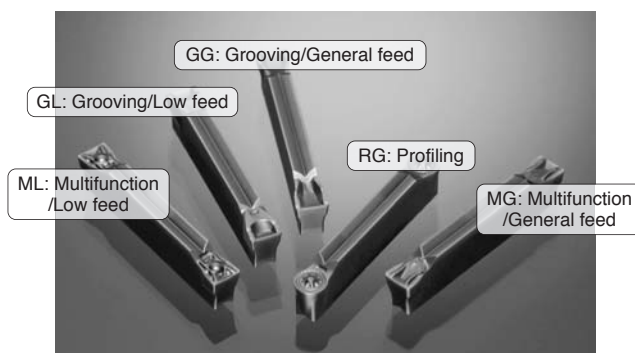

Photo 2. Insert lineup

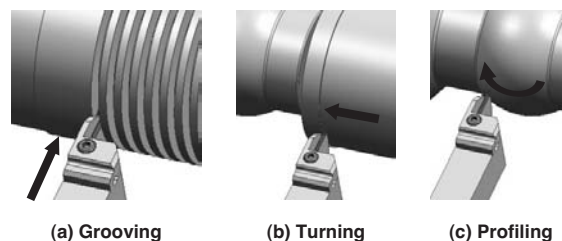

Fig. 1. Machining types with a grooving tool

GND grooving tools exhibit high chip control under various conditions of use.

During grooving, metal chips are not easily removed from the grooves formed because there is no available space for their removal, leading to the increased breakage of inserts and holders due to clogging by chips. We designed the insert chip breakers for the SEC-GND grooving tools to promote the removal of metal chips from grooves.

The shapes of the insert chip breakers were optimized by simulation using the finite element method (FEM)^{*1} to achieve the following two goals: (1) to reduce the width of chips generated to smaller than the groove width so that the chips do not easily come into contact with both sides of the grooves and (2) to control the radius of the curl formed by chips (curl radius) to an appropriate size (Figs. 2(a) and 3).

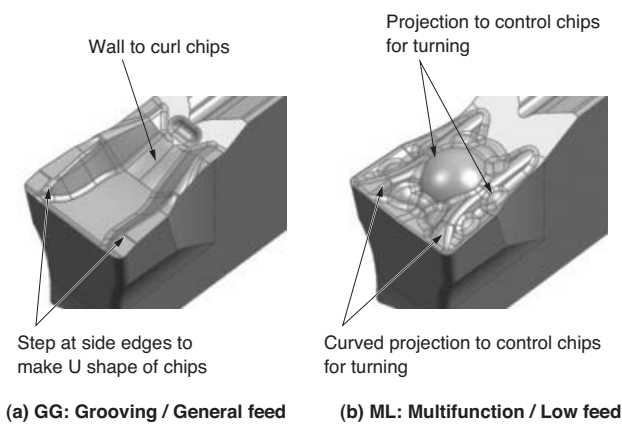

Fig. 2. Design of chip breakers

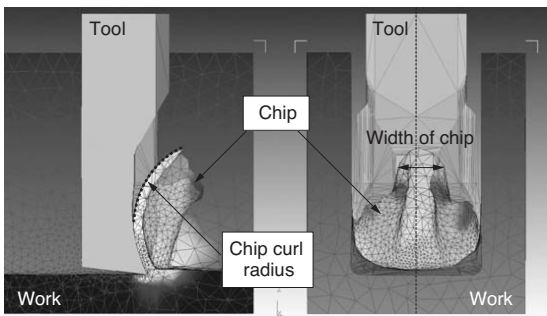

Fig. 3. Simulated chip shape in grooving

In addition, a curved structure was formed on both sides of the inserts used for multifunction machining (grooving/turning), as shown in Fig. 2(b). Thus, the inserts achieved high chip control during both grooving and turning.

2-2 Suppression of chatter vibration

Vibration more easily occurs during grooving than during general cutting because a cutting force is applied

to the entire cutting edge during grooving. Vibration of a tool during machining deteriorates the machined surface and causes problems such as unexpected breakage. Therefore, special high-rigidity steel is used as the holder material of the SEC-GND grooving tools and the sections from the insert clamp to the shank are combined into a single simpler structure, as shown in Fig. 4. In addition, the force used to clamp the insert has been increased without decreasing the high rigidity of the special steel by optimizing the shape of the clamp surface and the position of the bolt clamp (Fig. 5).

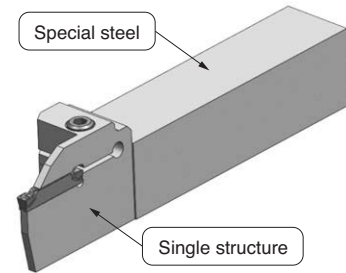

Fig. 4. Structure of SEC-GND grooving tool

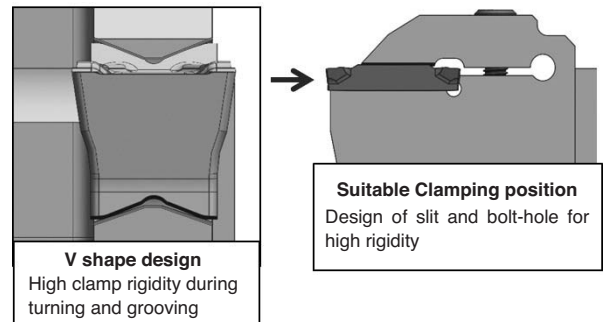

Fig. 5. Structure for clamping inserts

The vibrational characteristics of the holder were evaluated in a hammering test to confirm the effect of the designed structure on suppressing vibration. Figure 6 shows the method of evaluation used in this study. The compliance shown in Fig. 7 was the focus of the evaluation. Compliance represents the displacement of a target object for a unit excitation force and is expressed as a function of frequency. When compliance is expressed as a complex variable, the real part of compliance reaches a peak at a frequency close to the natural frequency then sharply decreases to a negative peak, as shown in Fig. 7. In general, chatter vibration more easily occurs as the absolute value of the negative peak becomes large, and therefore, we compared the negative peak of compliance among various holders⁽¹⁾.

Figure 8 shows the results of the evaluation. The SEC-GND grooving tool showed a negative peak of the real part

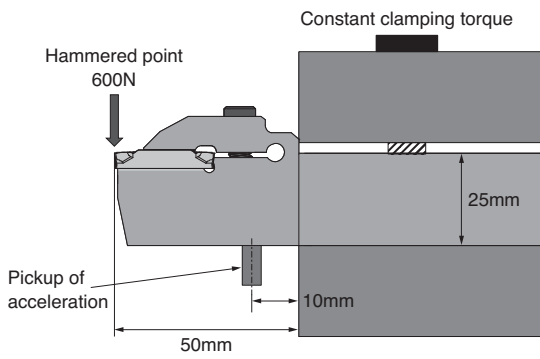

Fig. 6. Method of hammering test

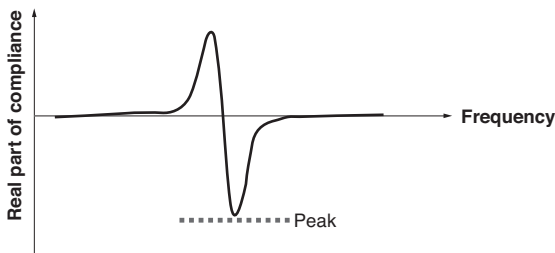

Fig. 7. Negative peak of real part of compliance

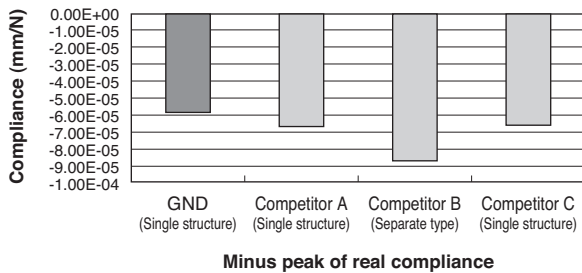
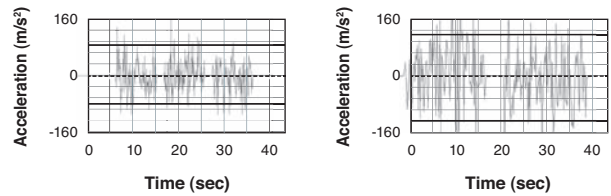

Fig. 8. Comparison of negative peak

of compliance that was smaller than that for competitors' products. In particular, the negative peak for the SEC-GND grooving tool was 35% smaller than that for tool B, produced by a competitor, which employs a separate type, indicating that our product is highly effective for suppressing vibration owing to its single structure.

The vibration of the holder during grooving was evaluated to confirm its effect on suppressing vibration during grooving. The results revealed that the vibration of the holder of the SEC-GND grooving tools during grooving was reduced by up to about 30% compared with that of a conventional tool with a separate structure (Fig. 9). Moreover, the vibration of the holder of the SEC-GND grooving tools during turning was also markedly reduced (Fig. 10).

Thus, vibration can be suppressed even during high-efficiency machining with a high feed speed, resulting in stable machining with a long tool life that will cause fewer problems such as unexpected breakage.



(a) GND

(b) Conventional tool / separate type

Workpiece: SCM415

Cutting conditions: $V_c=100\text{m/min}$, $f=0.1\text{mm/rev}$, $a_p=20\text{mm}$, wet

Tool: GNDLR2525M-220, GCMN2002-GG/AC530U

Fig. 9. Comparison of holder vibration during grooving

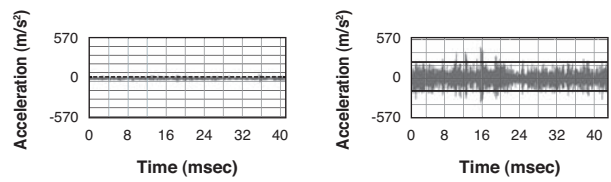

(a) GND

(b) Conventional tool

Workpiece: SCM420

Cutting conditions: $V_c=100\text{m/min}$, $f=0.2\text{mm/rev}$, $a_p=0.5\text{mm}$, wet

Tool: GNDMR2525M-312, GCMN3004-MG/AC530U

Fig. 10. Comparison of holder vibration during turning

2-3 High economic efficiency and accuracy

Conventionally, it has been essential to grind the outer surface of inserts used for grooving during their manufacture when high accuracy is required for the widths of grooves. However, controlling the width of the cutting edge is difficult in the case of using long thin inserts for deep grooving, such as those used with the SEC-GND grooving tools, because of their length. To overcome this problem, we have developed a high-accuracy sintering technology for the SEC-GND grooving tools that realizes a cutting edge with an accuracy of $\pm 0.03\text{mm}$ for the overall width without grinding (Fig. 11).

Thus, highly economical inserts that are manufactured without grinding can be used even in the cases of machining where ground inserts have conventionally been required.

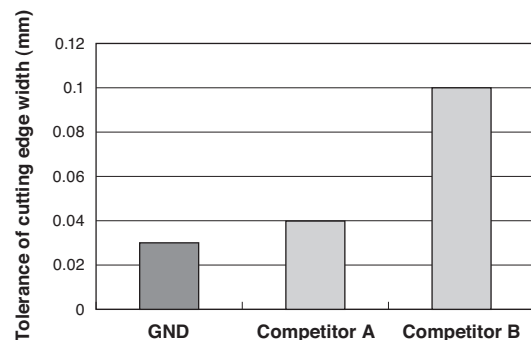

Fig. 11. Comparison of cutting edge width accuracy

3. Cutting Performance

The SEC-GND grooving tools can be used for various machining applications by selecting suitable combinations of holders and insert breakers. **Figures 12-14** show examples of uses of the SEC-GND grooving tools by our customers.

Figure 12 shows an example of grooving the outer surface of a component of an appliance used in the office (example i). When a conventional tool was used, step-feed grooving was necessary for breaking the formed chips because of low chip control. In contrast, when a SEC-GND grooving tool was used, chips were stably removed even during continuous-feed grooving because of its high chip control. This saved the time required for step-feed grooving and improved the machining efficiency by 2.5-fold.

Figure 13 shows an example of grooving and finishing the outer surface of a gear sprocket (example ii). When a conventional tool was used, chip control was unstable and unexpected breakage occurred at the insert of the tool because of its vibration during grooving. In contrast, when a SEC-GND grooving tool was used, no such breakage occurred at the insert because of its high chip control and effect on reducing vibration, resulting in a stable tool lifetime.

(a) Tooling

Workpiece: SCM440
 Tool holder: GNDLR2525M-320
 Insert: GCMN3002-GG / AC530U
 Cutting conditions: $V_c=90\text{m/min}$, $f=0.1\text{mm/rev}$, wet

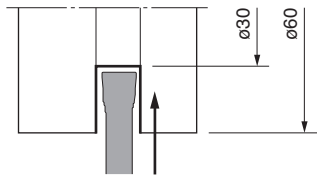

(b) Chips



GND

Conventional tool

(c) Machining efficiency

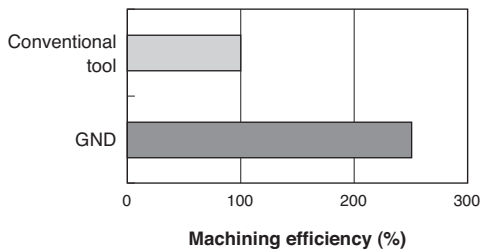

Fig. 12. Application example (i)

(a) Tooling

Workpiece: SCr415
 Tool holder: GNDMR2020K-518
 Insert: GCMN5008-MG / AC530U
 Cutting conditions: $V_c=150\text{m/min}$, $f=0.1\text{mm/rev}$, wet

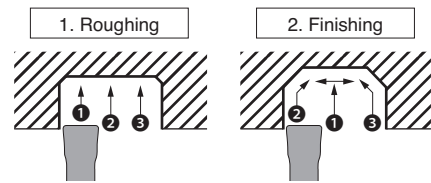
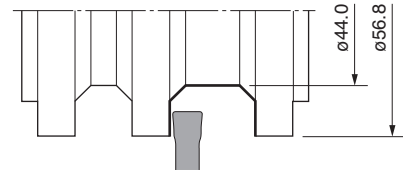
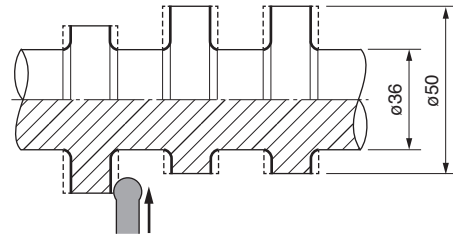

Fig. 13. Application example (ii)

(a) Tooling

Workpiece: S53C
 Tool holder: GNDML2525M-618
 Insert: GCMN6030-RG / AC530U
 Cutting conditions: $V_c=130\text{m/min}$, $f=0.36\text{mm/rev}$, wet



(b) Comparison of cutting edge damage

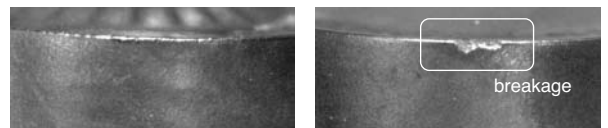

GND

Conventional tool

(c) Tool life

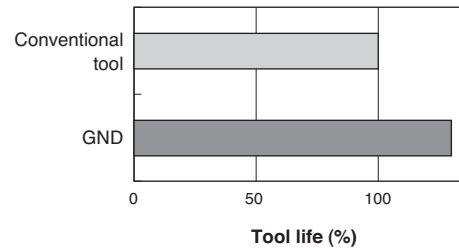

Fig. 14. Application example (iii)

Figure 14 shows an example of grooving and finishing the outer surface of a crank (example iii). When a conventional tool was used, unexpected breakage occurred at the insert of the tool because of its vibration during machining and high cutting resistance due to the shape of the cutting edge. In contrast, when a SEC-GND grooving tool was used, such breakage was prevented owing to its effect on reducing vibration and the appropriate shape of the cutting edge, resulting in a tool lifetime 1.3-fold longer than that of the conventional tool.

4. Conclusion

The SEC-GND grooving tools are highly economical, meet the market requirements, and enable high-efficiency stable machining. We believe that the SEC-GND grooving tools will contribute to improving the productivity of users and reducing the cost of tools.

Technical Term

*1 FEM (Finite Element Method): The finite element method (FEM) is a method of numerical analysis for approximately determining the overall behavior of an object by dividing it into small elements then summing up the calculation results for all elements.

References

- (1) T. Sugita, K. Ueda, and T. Inamura: Basis of Machining I – Basic Cutting, Kyoritsu Shuppan Co., Ltd. (1984) [in Japanese].

Contributors (The lead author is indicated by an asterisk (*).)

Y. SHIMAMOTO*

- Tool Designing Department, Sumitomo Electric Hardmetal Corp.
Engaged in the development of indexable tools for turning.



M. UEDA

- Section Specialist
Tool Designing Department, Sumitomo Electric Hardmetal Corp.

T. FUKUYAMA

- Product Development Department, Hokkaido Sumiden Precision Co., Ltd.

J. OKIDA

- Doctor of Engineering
Manager, Tool Designing Department, Sumitomo Electric Hardmetal Corp.